

SPEC for Mass Production

Spec No.	TQ3C-8EAF0-E1YAB42-01
Date	December 19, 2025

TYPE : TCG085WVLQHPNN-GN00

<8.5 inch WVGA transmissive color TFT with LED backlight>

CONTENTS

1. Application
2. Construction and outline
3. Mechanical specifications
4. Absolute maximum ratings
5. Electrical characteristics
6. Optical characteristics
7. Interface signals
8. Input timing characteristics
9. Backlight characteristics
10. Lot number identification
11. Warranty
12. Precautions for use
13. Reliability test data
14. Outline drawing



KYOCERA CORPORATION

This specification is subject to change without notice.
Consult Kyocera before ordering.

Original Issue Date	Designed by: Engineering dept.			Confirmed by: QA dept.
	Prepared	Checked	Approved	Approved
November 4, 2025	<i>K. Komurasaki</i>	<i>Y. Hata</i>	<i>I. Kawajiri</i>	<i>T. Sawada</i>

Warning

1. This Kyocera LCD module has been specifically designed for use only in electronic devices and industrial machines in the area of audio control, office automation, industrial control, home appliances, etc. The module should not be used in applications where the highest level of safety and reliability are required and module failure or malfunction of such module results in physical harm or loss of life, as well as enormous damage or loss. Such fields of applications include, without limitation, medical, aerospace, communications infrastructure, atomic energy control. Kyocera expressly disclaims any and all liability resulting in any way to the use of the module in such applications.

2. Customer agrees to indemnify, defend and hold Kyocera harmless from and against any and all actions, claims, damages, liabilities, awards, costs, and expenses, including legal expenses, resulting from or arising out of Customer's use, or sale for use, or Kyocera modules in applications.

Caution

1. Kyocera shall have the right, which Customer hereby acknowledges, to immediately scrap or destroy tooling for Kyocera modules for which no Purchase Orders have been received from the Customer in a two-year period.

2. Please note that we may not be able to respond to new environmental regulations after receiving the final mass production order for this product.

Spec No. TQ3C-8EAF0-E1YAB42-01	Part No. TCG085WVLQHPNN-GN00	Page -
-----------------------------------	---------------------------------	-----------

Revision record

Date		Designed by: Engineering dept.			Confirmed by: QA dept.
		Prepared	Checked	Approved	Approved
December 19, 2025		<i>K. Komurasaki</i>	<i>Y. Hata</i>	<i>I. Kawajiri</i>	<i>T. Sawada</i>
Rev. No.	Date	Page	Descriptions		
01	Dec. 19, 2025	1	3. Mechanical specifications Revised thickness specifications and notes		

1. Application

This document defines the specification of TCG085WVLQHPNN-GN00. (RoHS Compliant)

2. Construction and outline

LCD	: Transmissive color dot matrix type TFT
Backlight system	: LED
Polarizer	: Glare treatment
Additional circuit	: Timing controller, Power supply (3.3V input) (without constant current circuit for LED Backlight)

3. Mechanical specifications

Item	Specification	Unit
Outline dimensions 1)	210(W)×134(H)×8.7 (partially 9.1)(D)	mm
Active area	184.8(W)×110.88(H) (21.6 cm/8.5 inch(Diagonal))	mm
Dot format	800×(B,G,R)(W)×480(H)	dot
Dot pitch	0.077(W)×0.231(H)	mm
Base color 2)	Normally Black	-
Mass	310	g

- 1) Please refer to outline drawing for details.
- 2) Due to the characteristics of the LCD material, the color varies with environmental temperature.

4. Absolute maximum ratings

4-1. Electrical absolute maximum ratings

Item	Symbol	Min.	Max.	Unit
Supply voltage	V _{DD}	-0.3	4.0	V
Input signal voltage 1)	V _{IN}	-0.3	4.5	V
LED forward current 2) 3)	I _F	-	100	mA

1) Input signal : CK, R0~R5, G0~G5, B0~B5, H_{SYNC}, V_{SYNC}, ENAB, CM, SC

2) For each "AN-CA"

3) Do not apply reversed voltage.

4-2. Environmental absolute maximum ratings

Item	Symbol	Min.	Max.	Unit
Operating temperature 1)	T _{OP}	-20	70	°C
Storage temperature 2)	T _{STO}	-30	80	°C
Operating humidity 3)	H _{OP}	10	4)	%RH
Storage humidity 3)	H _{STO}	10	4)	%RH
Vibration	-	5)	5)	-
Shock	-	6)	6)	-

1) Operating temperature range defines the operation only and the contrast, response time and other display optical characteristics are set at Ta (Ambient Temperature) =25°C.

2) Ta= -30°C < 48h, Ta= 80°C < 168h

Store LCD at normal temperature/humidity. Keep them free from vibration and shock.

An LCD that is kept at a low or a high temperature for a long time can be defective due to other conditions, even if the low or high temperature satisfies the standard.

(Please refer to "Precautions for Use" for details.)

3) Non-condensing

4) Ta ≤ 40°C, 85%RH Max.

Ta > 40°C, Absolute humidity shall be less than 85%RH at 40°C.

5)

Frequency	10~55 Hz	Acceleration value (0.3~9 m/s ²)
Vibration width	0.15mm	
Interval	10-55-10 Hz	1 minute

2 hours in each direction X, Y, Z (6 hours total)

EIAJ ED-2531

6) Acceleration: 490 m/s², Pulse width: 11 ms

3 times in each direction: ±X, ±Y, ±Z

EIAJ ED-2531

5. Electrical characteristics

Ta = -20~70°C

Item	Symbol	Condition	Min.	Typ.	Max.	Unit	
Supply voltage	V _{DD}	-	3.0	3.3	3.6	V	
Current consumption	I _{DD}	2)	-	200	260	mA	
Permissible input ripple voltage	V _{RP}	V _{DD} =3.3V	-	-	100	mVp-p	
Input signal voltage	3)	V _{IL}	"Low" level	0	-	0.8	V
		V _{IH}	"High" level	2.0	-	V _{DD}	V
	4)	V _{IL}	"Low" level	0	-	0.3V _{DD}	V
		V _{IH}	"High" level	0.7V _{DD} -	-	V _{DD}	V

1) V_{DD}-turn-on conditions

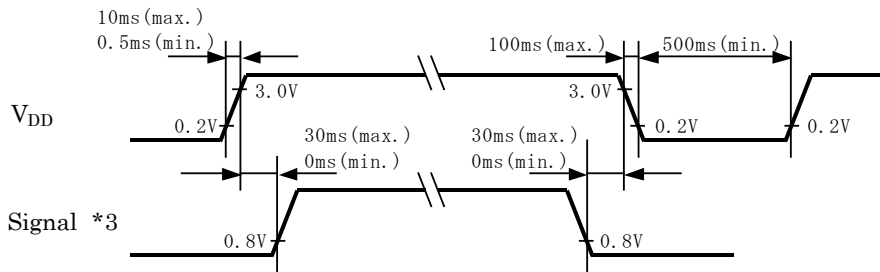

2) Display pattern:

V_{DD} = 3.3V, Ta = 25°C

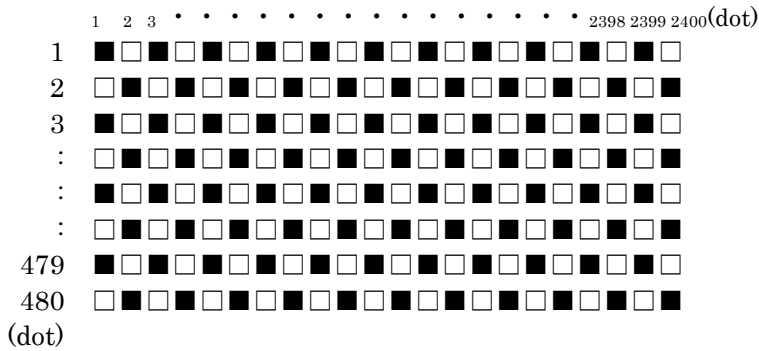

3) Input signal: CK, R0~R5, G0~G5, B0~B5, H_{SYNC}, V_{SYNC}, ENAB, CM

4) Input signal: SC

6. Optical characteristics

Measuring spot = ϕ 6.0mm, Ta= 25°C

Item	Symbol	Condition	Min.	Typ.	Max.	Unit	
Response time	Rise	τ_r	$\theta = \phi = 0^\circ$	-	12	-	ms
	Down	τ_d	$\theta = \phi = 0^\circ$	-	18	-	ms
Viewing angle range	θ UPPER	CR \geq 10	-	85	-	deg.	
	θ LOWER		-	85	-		
	ϕ LEFT		-	85	-	deg.	
	ϕ RIGHT		-	85	-		
Contrast ratio	CR	$\theta = \phi = 0^\circ$	350	500	-	-	
Brightness	L	IF=60mA/Line	280	400	-	cd/m ²	
Chromaticity coordinates	Red	x	$\theta = \phi = 0^\circ$	0.550	0.600	0.650	-
		y		0.300	0.350	0.400	
	Green	x	$\theta = \phi = 0^\circ$	0.285	0.335	0.385	
		y		0.515	0.565	0.615	
	Blue	x	$\theta = \phi = 0^\circ$	0.100	0.150	0.200	
		y		0.065	0.115	0.165	
	White	x	$\theta = \phi = 0^\circ$	0.260	0.310	0.360	
		y		0.275	0.325	0.375	

6-1. Definition of contrast ratio

$$\text{CR(Contrast ratio)} = \frac{\text{Brightness with all pixels "White"}}{\text{Brightness with all pixels "Black"}}$$

6-2. Definition of response time

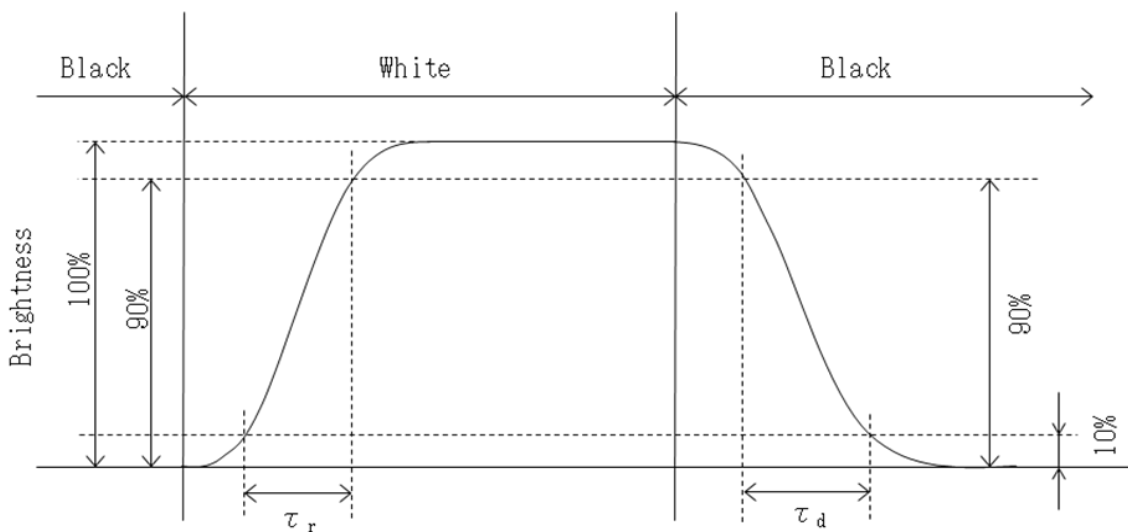

6-3. Definition of viewing angle

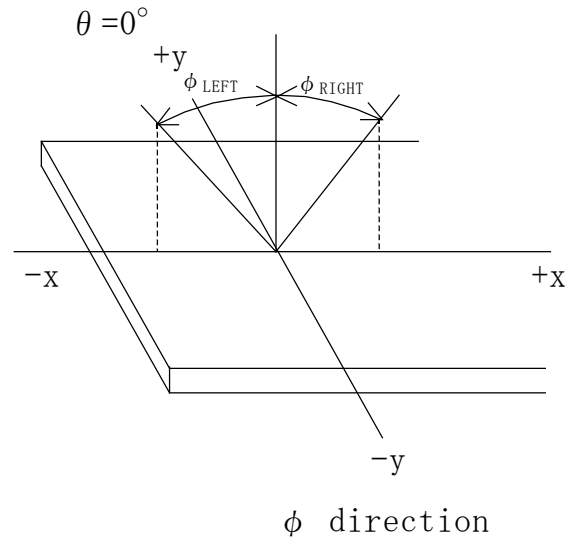
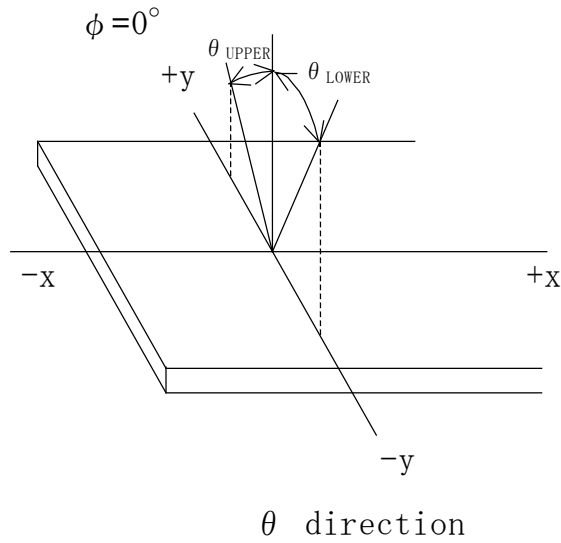

6-4. Brightness measuring point

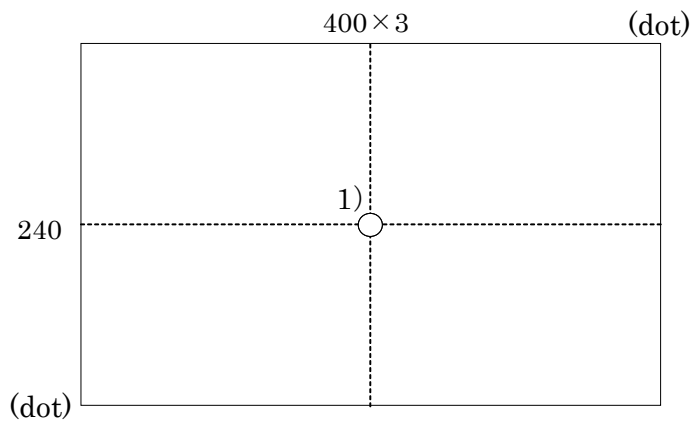

- 1) Rating is defined as the white brightness at center of display screen.
- 2) 5 minutes after LED is turned on. ($T_a=25^\circ\text{C}$)

7. Interface signals

7-1. LCD

No.	Symbol	Description	Level
1	V _{DD}	3.3V power supply	
2	V _{DD}	3.3V power supply	
3	V _{DD}	3.3V power supply	
4	V _{DD}	3.3V power supply	
5	CM	Mode select signal(High or Open: Necessity of V·H _{SYNC} , GND: Unnecessity of V·H _{SYNC})	
6	ENAB	Data Enable signal(positive)	
7	GND	GND	
8	V _{SYNC}	Vertical synchronous signal (negative) (fix low or high: when CM fixed to GND)	
9	GND	GND	
10	H _{SYNC}	Horizontal synchronous signal (negative) (fix low or high: when CM fixed to GND)	
11	GND	GND	
12	B5	BLUE data signal (MSB)	
13	B4	BLUE data signal	
14	B3	BLUE data signal	
15	GND	GND	
16	B2	BLUE data signal	
17	B1	BLUE data signal	
18	B0	BLUE data signal (LSB)	
19	GND	GND	
20	G5	GREEN data signal (MSB)	
21	G4	GREEN data signal	
22	G3	GREEN data signal	
23	GND	GND	
24	G2	GREEN data signal	
25	G1	GREEN data signal	
26	G0	GREEN data signal (LSB)	
27	GND	GND	
28	R5	RED data signal (MSB)	
29	R4	RED data signal	
30	R3	RED data signal	
31	GND	GND	
32	R2	RED data signal	
33	R1	RED data signal	
34	R0	RED data signal (LSB)	
35	SC	Scan direction control	
36	GND	GND	
37	GND	GND	
38	CK	Clock signal	
39	GND	GND	
40	GND	GND	

LCD connector (CN1) : FH33-40S-0.5SH (10) (HIROSE)

Recommended matching FFC or FPC : 0.5mm pitch

1) Scan direction

SC : GND or Open

SC : High

Scan direction

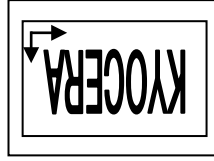

7-2. LED

No.	Symbol	Description
1	AN1	Anode 1
2	AN2	Anode 2
3	CA1	Cathode 1
4	CA2	Cathode 2

LCD side connector (CN2) : PHR-4

(JST)

Recommended matching connector (CN2)

: B4B-PH-SM4-TB

(JST)

: B4B-PH-SM4-TB(LF)(SN)

(JST)···(RoHS Compliant)

: S4B-PH-SM4-TB

(JST)

: S4B-PH-SM4-TB(LF)(SN)

(JST)···(RoHS Compliant)

8. Input timing characteristics

8-1. CM : High or Open (Necessity of V_{H SYNC})

8-1-1. Timing characteristics 1), 3), 4)

Item		Symbol	Min.	Typ.	Max.	Unit	Note
Clock signal (CK)	Frequency	Fck	29.88	33.2	36.52	MHz	2)
	Period	Tc	27.4	30.1	33.5	ns	
	High time	Tch	12	-	-	ns	
	Low time	Tcl	12	-	-	ns	
Data signal (R0~R5, G0~G5, B0~B5)	Set up time	Tds	5	-	-	ns	
	Hold time	Tdh	10	-	-	ns	
Data Enable signal (ENAB)	Set up time	Tes	5	-	-	ns	
	Hold time	Teh	10	-	-	ns	
Horizontal sync. signal (H _{SYNC})	Set up time	Ths	5	-	-	ns	
	Hold time	Thh	10	-	-	ns	
	Period	Th	944	1056	1088	Tc	5), 6)
			-	31.8	-	μs	5)
	Pulse width	Thp	4	128	-	Tc	5), 6)
	Front porch	Thf	-	40	-	Tc	6)
	Back porch	Thb	7	88	-	Tc	6)
Horizontal display period	Thd	800			Tc	6)	
Vertical sync. signal (V _{SYNC})	Period	Tv	516	525	534	Th	5)
			14.7	16.6	17.4	ms	
	Pulse width	Tvp	1	2	-	Th	
	Front porch	Tvf	-	11	-	Th	
Back porch	Tvb	4	32	-	Th		
Vertical display period	Tvd	480			Th		

- 1) In case of lower frequency, the deterioration of the display quality, flicker etc., may occur.
- 2) If CK is fixed to "H" or "L" level for certain period while ENAB is supplied, the panel may be damaged.
- 3) When dimming LED by PWM, please adjust LCD operating signal timing and LED driving frequency, to optimize the display quality. There is a possibility that flicker is observed by the interference of LCD operating signal timing and LED driving condition (especially driving frequency), even if the condition satisfies above timing specification.
- 4) Do not make Tv, Th, and Thp fluctuate.
- 5) CK count of each Horizontal Scanning Time should be always the same.
Vertical invalid data period should be "n" X "Horizontal Scanning Time". (n: integer)
Frame period should be always the same.

8-2. CM : GND (Unnecessity of V·H_{SYNC})

8-2-1. Timing characteristics 1), 3), 4)

Item		Symbol	Min.	Typ.	Max.	Unit	Note
Clock signal (CK)	Frequency	Fck	29.88	33.2	36.52	MHz	2)
	Period	Tc	27.4	30.1	33.5	ns	
	High time	Tch	12	-	-	ns	
	Low time	Tcl	12	-	-	ns	
Data signal (R0~R5, G0~G5, B0~B5)	Set up time	Tds	5	-	-	ns	
	Hold time	Tdh	10	-	-	ns	
Data Enable signal (ENAB)	Set up time	Tes	5	-	-	ns	
	Hold time	Teh	10	-	-	ns	
	Period	Th	1024	1056	1088	Tc	5), 6)
			-	31.8	-	μs	5)
	Horizontal display period	Thd	800			Tc	6)
	Period	Tv	487	525	550	Th	5)
			14.7	16.6	17.4	ms	
Vertical display period	Tvd	480			Th		

- 1) In case of lower frequency, the deterioration of the display quality, flicker etc., may occur.
- 2) If CK is fixed to "H" or "L" level for certain period while ENAB is supplied, the panel may be damaged.
- 3) When dimming LED by PWM, please adjust LCD operating signal timing and LED driving frequency, to optimize the display quality. There is a possibility that flicker is observed by the interference of LCD operating signal timing and LED driving condition (especially driving frequency), even if the condition satisfies above timing specification.
- 4) Do not make Tv, Th, and Thp fluctuate.
- 5) CK count of each Horizontal Scanning Time should be always the same.
Vertical invalid data period should be "n" X "Horizontal Scanning Time". (n: integer)
Frame period should be always the same.

8-2-2. Input timing characteristics

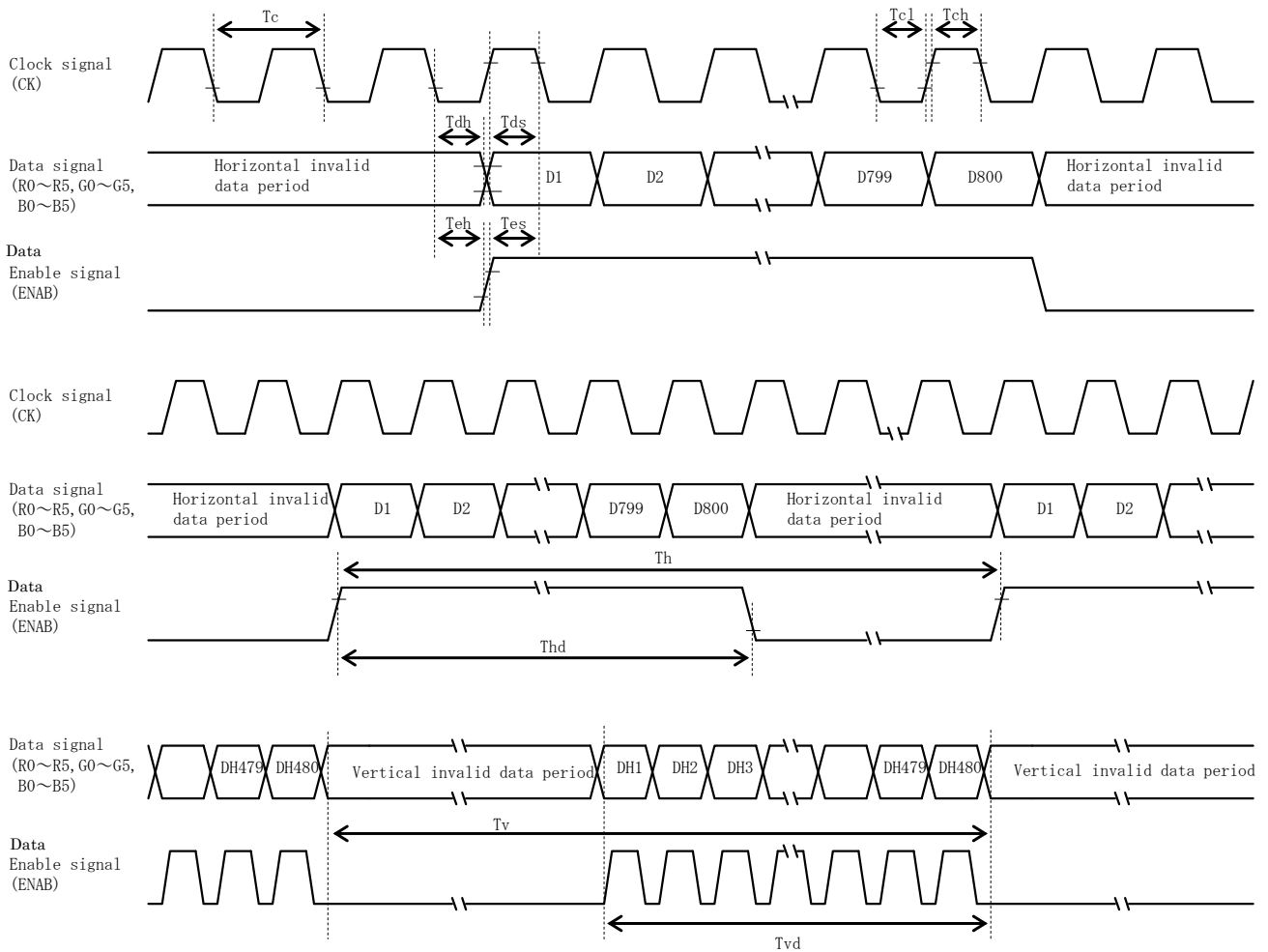

8-3. Input data signals and display position on the screen

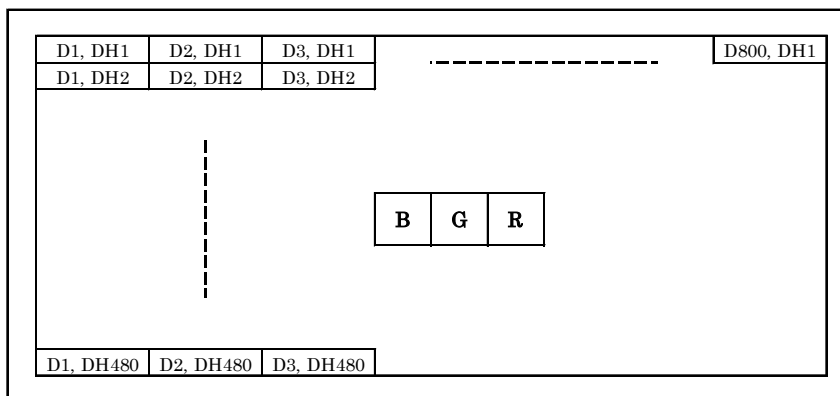

9. Backlight characteristics

Item	Symbol	Min.	Typ.	Max.	Unit	Note
Forward current 1)	IF	-	60	-	mA	Ta=-20~70°C
Forward voltage 1)	VF	-	29.2	32.0	V	IF=60mA, Ta=-20°C
		-	27.7	30.6	V	IF=60mA, Ta=25°C
		-	26.8	29.7	V	IF=60mA, Ta=70°C
Operating life time 2), 3)	T	-	100,000	-	h	IF=60mA, Temp.=25°C

- 1) For each "AN-CA"
- 2) When brightness decrease 50% of minimum brightness.
The average life of LED will decrease when the LCD is operating at higher temperatures.
- 3) Life time is estimated data. (Condition: IF=60mA, Temp.=25°C in chamber).
- 4) An input current below 15mA may reduce the brightness uniformity of the LED backlight.
This is because the amount of light from each LED chip is different. Therefore, please evaluate carefully before finalizing the input current.
- 5) LED formation: 9 series, 2 parallel

Spec No.	Part No.	Page
TQ3C-8EAF0-E1YAB42-01	TCG085WVLQHPNN-GN00	14

12. Precautions for use

12-1. Installation of the LCD

- 1) A transparent protection plate shall be added to protect the LCD and its polarizer.
- 2) The LCD shall be installed so that there is no pressure on the LSI chips.
- 3) Since this product is wide viewing product, occurrence level of in-plane unevenness by the external stress is different compared to current normal viewing product. So there is a possibility that in-plane unevenness will be occurred by over twist, strain giving by attaching to LCD, and over pressure to touch panel. Please be careful of stress when designing the housing.
- 4) A transparent protection film is attached to the polarizer. Please remove the protection film slowly before use, paying attention to static electricity.

12-2. Static electricity

- 1) Since CMOS ICs are mounted directly onto the LCD glass, protection from static electricity is required.
- 2) Workers should use body grounding. Operator should wear ground straps.

12-3. LCD operation

- 1) The LCD shall be operated within the limits specified. Operation at values outside of these limits may shorten life, and/or harm display images.
- 2) Please select the best display pattern based on your evaluation because flicker, lines or nonuniformity or unevenness can be visible depending on display patterns.

12-4. Storage

- 1) The LCD shall be stored within the temperature and humidity limits specified.
Store in a dark area, and protect the LCD from direct sunlight or fluorescent light.
- 2) Always store the LCD so that it is free from external pressure onto it.

12-5. Usage

- 1) **DO NOT** store in a high humidity environment for extended periods. Polarizer degradation bubbles, and/or peeling off of the polarizer may result.
- 2) The front polarizer is easily scratched or damaged. Prevent touching it with any hard material, and from being pushed or rubbed.
- 3) The LCD screen may be cleaned by wiping the screen surface with a soft cloth or cotton pad using a little Ethanol.
- 4) Water may cause damage or discoloration of the polarizer. Clean condensation or moisture from any source immediately.
- 5) Always keep the LCD free from condensation during testing. Condensation may permanently spot or stain the polarizer.
- 6) Do not disassemble LCD because it will result in damage.
- 7) This Kyocera LCD has been specifically designed for use in general electronic devices, but not for use in a special environment such as usage in an active gas. Hence, when the LCD is supposed to be used in a special environment, evaluate the LCD thoroughly beforehand and do not expose the LCD to chemicals such as an active gas.
- 8) Please do not use solid-base image pattern for long hours because a temporary afterimage may appear. We recommend using screen saver etc. in cases where a solid-base image pattern must be used.
- 9) Liquid crystal may leak when the LCD is broken. Be careful not to let the fluid go into your eyes and mouth. In the case the fluid touches your body; rinse it off right away with water and soap.

13. Reliability test data

Test item	Test condition	Test time	Judgement
High temp. atmosphere	80°C	240h	Display function : No defect Display quality : No defect Current consumption : No defect
Low temp. atmosphere	-30°C	240h	Display function : No defect Display quality : No defect Current consumption : No defect
High temp. humidity atmosphere	40°C 90% RH	240h	Display function : No defect Display quality : No defect Current consumption : No defect
Temp. cycle	-30°C 0.5h R.T. 0.5h 80°C 0.5h	10cycles	Display function : No defect Display quality : No defect Current consumption : No defect
High temp. operation	70°C	500h	Display function : No defect Display quality : No defect Current consumption : No defect

- 1) Each test item uses a test LCD only once. The tested LCD is not used in any other tests.
- 2) The LCD is tested in circumstances in which there is no condensation.
- 3) The reliability test is not an out-going inspection.
- 4) The result of the reliability test is for your reference purpose only.
The reliability test is conducted only to examine the LCD's capability.

No	Description	Drawn	Checked	Checked	Approved

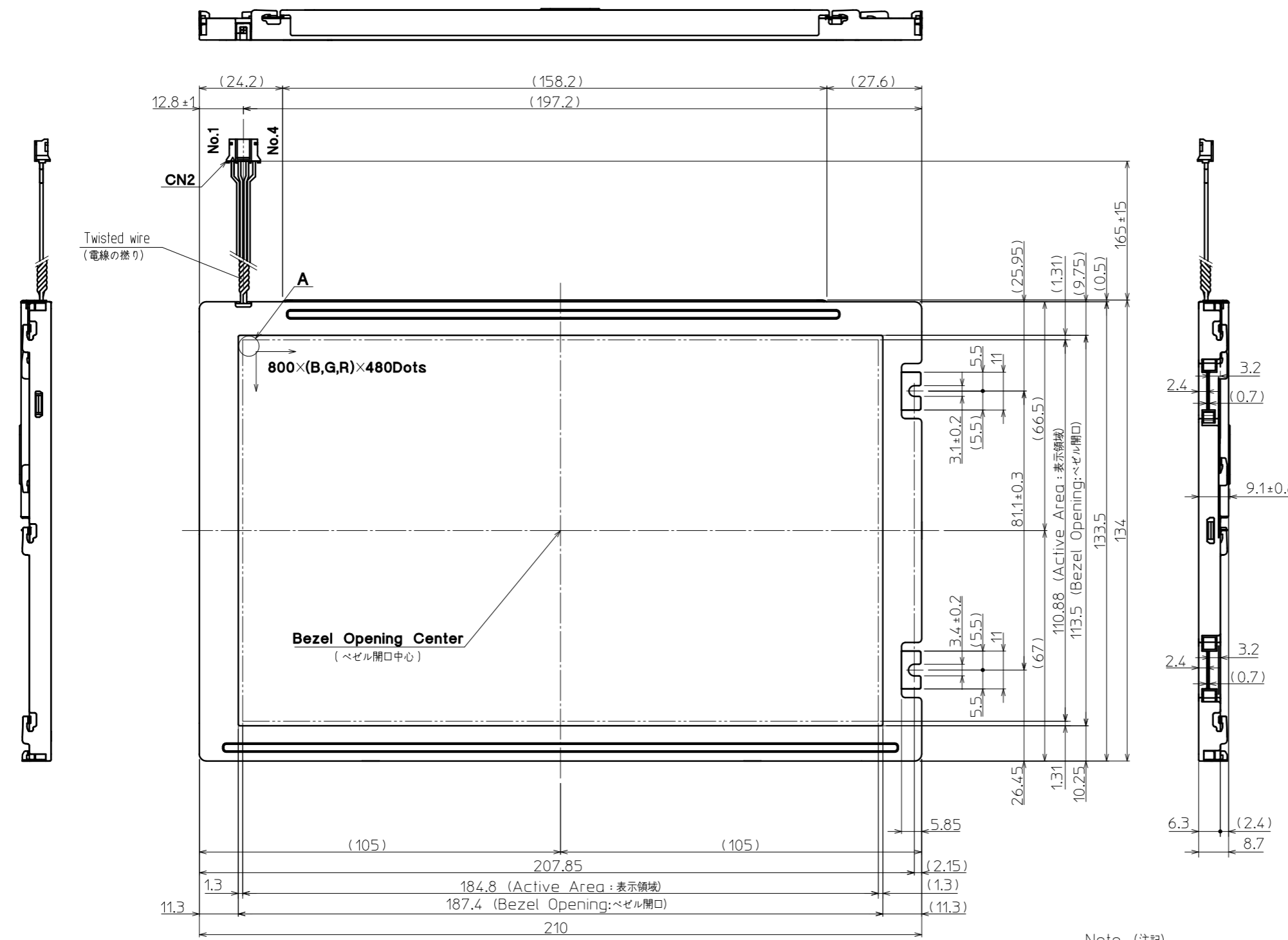

Twisted wire
(電線の撚り)

(24.2) (158.2) (27.6)
(197.2)

12.8±1

No.1 No.4

CN2

800×(B,G,R)×480Dots

Bezel Opening Center
(ベゼル開口中心)

3.1±0.2 (5.5) 5.5 11
81.1±0.3 (66.5)
110.88 (Active Area: 表示領域)
113.5 (Bezel Opening: ベゼル開口)

3.4±0.2 (5.5) 5.5 11
26.45 1.31 10.25

(105) (105) 5.85
207.85 (2.15)
1.3 184.8 (Active Area: 表示領域) (1.3)
187.4 (Bezel Opening: ベゼル開口) (11.3)
210

165±15

3.2 (0.7)
2.4
9.1±0.8
3.2 (0.7)
2.4
6.3 (2.4) 8.7

- Note. (注記)
- Connector CN1: FH33-40S-0.5SH (10) (HIROSE)
(コネクタ) CN2: PHR-4 (JST)
 - Matching Connector : B4B-PH-SM4-TB (JST)
(適合コネクタ) B4B-PH-SM4-TB(LF)(SN) (JST)
S4B-PH-SM4-TB (JST)
S4B-PH-SM4-TB(LF)(SN) (JST) etc.
 - The Information of LCD is displayed starting at the upper left hand corner, moving right then down to the lower right hand corner.
(LCDにおいて、画像データの表示は左上コーナーから始まり、右へ進み下へ送られ右下コーナーへ向かう.)
 - Tolerance without indication : ±0.5
(指示無き公差)
 - There is a possibility that in-plane unevenness will be occurred by over twist, stress giving by attaching to LCD, and over pressure to touch panel.
Please be careful of stress when designing the housing.
(過度な捻じり(ひずみ)、LCD固定時での応力発生、タッチパネルでの過度な押し圧によっては、パネル面内にムラが発生することがありますので、筐体設計において、事前に十分確認願います。)

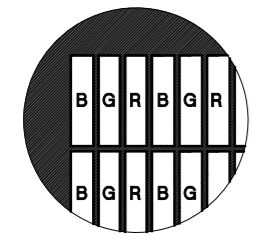

CN2 Pin Assign

	Cable Color
No.1	Black(黒)
No.2	Red(赤)
No.3	White(白)
No.4	Blue(青)

DETAIL A (Dot Size)
(NTS)

Material	Treatment	Approved	Checked	Checked	Drawn	Scale	Title	Year-Month-Day	Size
材質	処理	'25.10.31		'25.10.31	倉元	1:1 (NTS)	TCG085WVLQHPNN	'25.10.28	2
Quantity	Description; RoHS	加藤		本間			Outline Dimensions		1
製作数	備考 25052-08048						Drawing No. 121A9045000		2

No	Description	Drawn	Checked	Checked	Approved

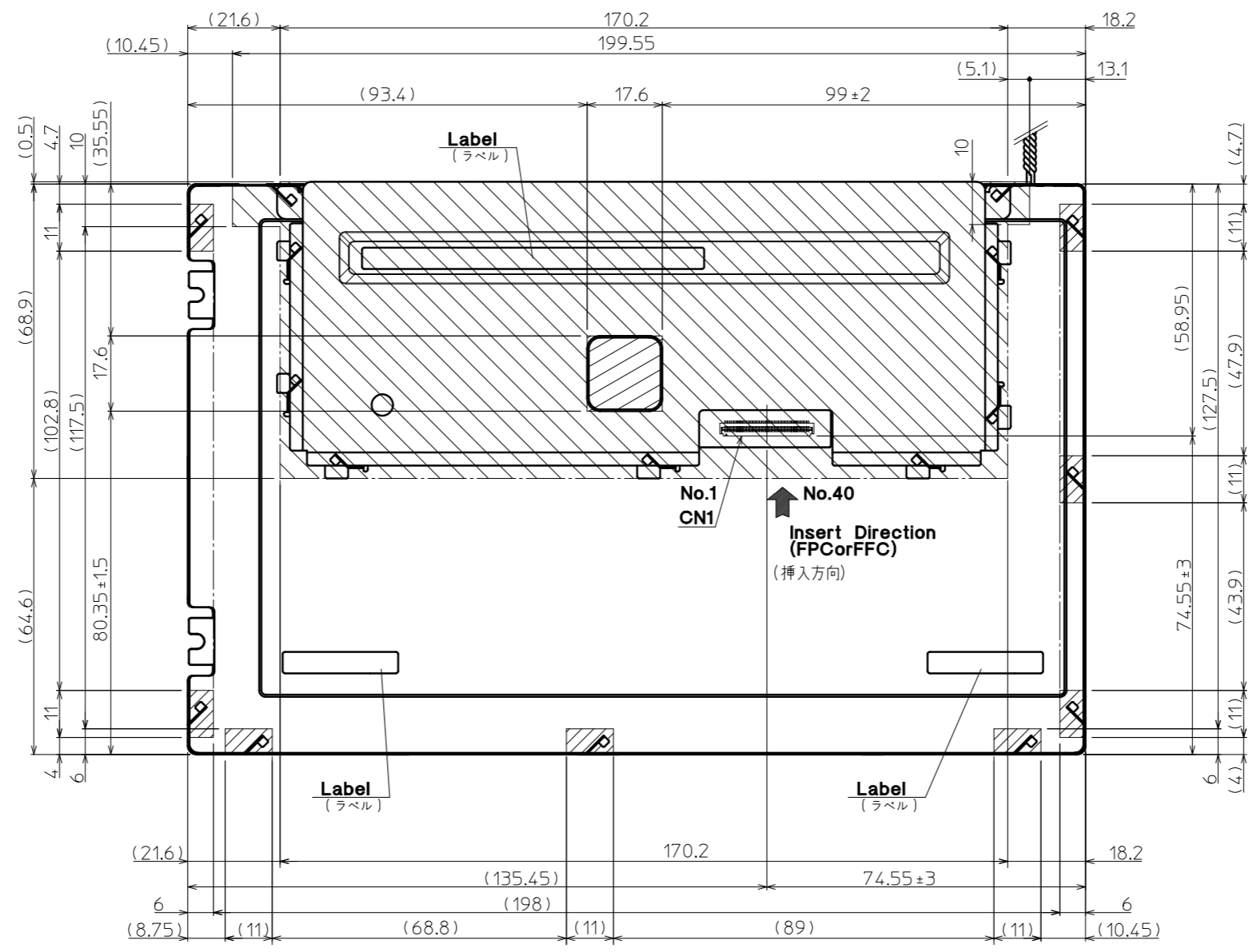

- : Projected part is 9.1mm thickness.
(厚み9.1mm)
- : Projected part is 8.7mm thickness.
(厚み8.7mm)
- : Projected part is 8.3mm thickness.
(厚み8.3mm)

Note. (注記)
1. Tolerance without indication : ±0.5
(指示無き公差)

Material 材質	Treatment 処理	Approved '25.10.31	Checked	Checked '25.10.31	Drawn 倉元	Scale 1:1 (NTS)	Title TCG085WVLQHPNN		Year-Month-Day '25.10.28	Size 2
Quantity 製作数	Description; 備考	RoHS 25052-08048	加藤	本間		Outline Dimensions	Drawing No. 121A9045000		2/2	

Spec No.	TQ3C-8EAF0-E2YAB42-00
Date	November 4, 2025

KYOCERA INSPECTION STANDARD

TYPE : TCG085WVLQHPNN-GN00

KYOCERA CORPORATION

Original Issue Date	Designed by: Engineering dept.			Confirmed by: QA dept.
	Prepared	Checked	Approved	Approved
November 4, 2025	<i>K. Komurasaki</i>	<i>Y. Hata</i>	<i>I. Kawajiri</i>	<i>T. Sawada</i>

Visuals specification

1) Note

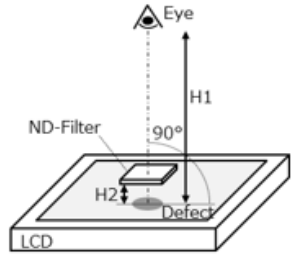
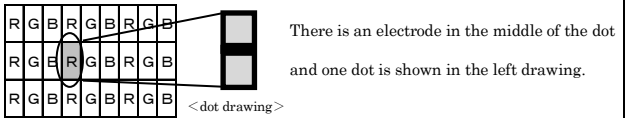
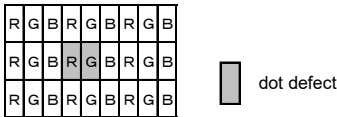
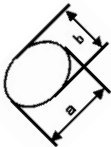
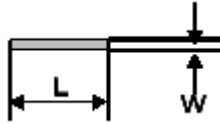
		Note		
General	<p>1. Customer identified anomalies not defined within this inspection standard shall be reviewed by Kyocera, and an additional standard shall be determined by mutual consent.</p> <p>2. This inspection standard about the image quality shall be applied to any defect within the active area and shall not be applicable to outside of the area.</p> <p>3. Luminance: 500 Lux min. Inspection distance (H1): 300 mm Distance between LCD panel surface and ND filter (H2): $0 < H2 < 30$ mm *ND filters are placed parallel to the LCD panel. Temperature: $25 \pm 5^\circ\text{C}$ Direction: Directly above</p>			
Definition of inspection item	Dot defect	Bright dot defect	<p>The dot is constantly “on” when power applied to the LCD, even when all “Black” data sent to the screen. Inspection tool: 5% Transparency neutral density filter. Count dot: If the dot is visible through the filter. Don't count dot: If the dot is not visible through the filter.</p> 	
		Black dot defect (including circular ones)	<p>The dot is constantly “off” when power applied to the LCD, even when all “White” data sent to the screen. Similar size compared to bright dot. Circular black dots shall be evaluated according to the criteria for circular white dots and circular black dots.</p>	
		White dot (Circular/foreign particle)	<p>Pixel works electrically, however, circular/foreign particle makes dot appear to be “on” even when all “Black” data is sent to the screen.</p>	
		Adjacent dot	<p>Adjacent dot defect is defined as two or more bright dot defects or black dot defects.</p> 	
	External inspection	Bubble, Scratch, Foreign particle (Polarizer, Cell, Backlight)	Visible operating (all pixels “Black” or “White”) and non operating.	
	Appearance inspection	Does not satisfy the value at the spec.		
Definition of size	<p>Definition of circle size</p>  <p>a: major axis, b: minor axis $d = (a + b) / 2$</p>	<p>Definition of linear size</p> 		

2) Standard

Classification		Inspection item		Judgement standard																
Defect (in LCD glass)	Single dot	Bright dot defect		Acceptable number	: 4															
		Black dot defect		Acceptable number	: 5															
	Adjacent dot	2 dots	Bright dot defect	Acceptable number	: 2															
			Black dot defect	Acceptable number	: 3															
		3 or more dots		Acceptable number	: 0															
	Total dot defects				Acceptable number	: 5 Max														
	Others	Circular white dots and circular black dots		<table border="1"> <thead> <tr> <th>Size (mm)</th> <th>Acceptable number</th> </tr> </thead> <tbody> <tr> <td>$d \leq 0.2$</td> <td>(Neglected)</td> </tr> <tr> <td>$0.2 < d \leq 0.4$</td> <td>5</td> </tr> <tr> <td>$0.4 < d \leq 0.5$</td> <td>3</td> </tr> <tr> <td>$0.5 < d$</td> <td>0</td> </tr> </tbody> </table>			Size (mm)	Acceptable number	$d \leq 0.2$	(Neglected)	$0.2 < d \leq 0.4$	5	$0.4 < d \leq 0.5$	3	$0.5 < d$	0				
Size (mm)	Acceptable number																			
$d \leq 0.2$	(Neglected)																			
$0.2 < d \leq 0.4$	5																			
$0.4 < d \leq 0.5$	3																			
$0.5 < d$	0																			
External inspection (Defect on Polarizer or between Polarizer and LCD glass)	Polarizer (Scratch)		<table border="1"> <thead> <tr> <th>Width (mm)</th> <th>Length (mm)</th> <th>Acceptable number</th> </tr> </thead> <tbody> <tr> <td>$W \leq 0.1$</td> <td>—</td> <td>(Neglected)</td> </tr> <tr> <td rowspan="2">$0.1 < W \leq 0.3$</td> <td>$L \leq 5.0$</td> <td>(Neglected)</td> </tr> <tr> <td>$5.0 < L$</td> <td>0</td> </tr> <tr> <td>$0.3 < W$</td> <td>—</td> <td>0</td> </tr> </tbody> </table>			Width (mm)	Length (mm)	Acceptable number	$W \leq 0.1$	—	(Neglected)	$0.1 < W \leq 0.3$	$L \leq 5.0$	(Neglected)	$5.0 < L$	0	$0.3 < W$	—	0	
	Width (mm)	Length (mm)	Acceptable number																	
	$W \leq 0.1$	—	(Neglected)																	
	$0.1 < W \leq 0.3$	$L \leq 5.0$	(Neglected)																	
		$5.0 < L$	0																	
	$0.3 < W$	—	0																	
	Polarizer (Bubble)		<table border="1"> <thead> <tr> <th>Size (mm)</th> <th>Acceptable number</th> </tr> </thead> <tbody> <tr> <td>$d \leq 0.2$</td> <td>(Neglected)</td> </tr> <tr> <td>$0.2 < d \leq 0.3$</td> <td>5</td> </tr> <tr> <td>$0.3 < d \leq 0.5$</td> <td>3</td> </tr> <tr> <td>$0.5 < d$</td> <td>0</td> </tr> </tbody> </table>			Size (mm)	Acceptable number	$d \leq 0.2$	(Neglected)	$0.2 < d \leq 0.3$	5	$0.3 < d \leq 0.5$	3	$0.5 < d$	0					
	Size (mm)	Acceptable number																		
	$d \leq 0.2$	(Neglected)																		
	$0.2 < d \leq 0.3$	5																		
$0.3 < d \leq 0.5$	3																			
$0.5 < d$	0																			
Foreign particle (Circular shape)		<table border="1"> <thead> <tr> <th>Size (mm)</th> <th>Acceptable number</th> </tr> </thead> <tbody> <tr> <td>$d \leq 0.2$</td> <td>(Neglected)</td> </tr> <tr> <td>$0.2 < d \leq 0.4$</td> <td>5</td> </tr> <tr> <td>$0.4 < d \leq 0.5$</td> <td>3</td> </tr> <tr> <td>$0.5 < d$</td> <td>0</td> </tr> </tbody> </table>			Size (mm)	Acceptable number	$d \leq 0.2$	(Neglected)	$0.2 < d \leq 0.4$	5	$0.4 < d \leq 0.5$	3	$0.5 < d$	0						
Size (mm)	Acceptable number																			
$d \leq 0.2$	(Neglected)																			
$0.2 < d \leq 0.4$	5																			
$0.4 < d \leq 0.5$	3																			
$0.5 < d$	0																			
Foreign particle (Linear shape) Scratch		<table border="1"> <thead> <tr> <th>Width (mm)</th> <th>Length (mm)</th> <th>Acceptable number</th> </tr> </thead> <tbody> <tr> <td>$W \leq 0.03$</td> <td>—</td> <td>(Neglected)</td> </tr> <tr> <td rowspan="3">$0.03 < W \leq 0.1$</td> <td>$L \leq 2.0$</td> <td>(Neglected)</td> </tr> <tr> <td>$2.0 < L \leq 4.0$</td> <td>3</td> </tr> <tr> <td>$4.0 < L$</td> <td>0</td> </tr> <tr> <td>$0.1 < W$</td> <td>—</td> <td>(According to circular shape)</td> </tr> </tbody> </table>			Width (mm)	Length (mm)	Acceptable number	$W \leq 0.03$	—	(Neglected)	$0.03 < W \leq 0.1$	$L \leq 2.0$	(Neglected)	$2.0 < L \leq 4.0$	3	$4.0 < L$	0	$0.1 < W$	—	(According to circular shape)
Width (mm)	Length (mm)	Acceptable number																		
$W \leq 0.03$	—	(Neglected)																		
$0.03 < W \leq 0.1$	$L \leq 2.0$	(Neglected)																		
	$2.0 < L \leq 4.0$	3																		
	$4.0 < L$	0																		
$0.1 < W$	—	(According to circular shape)																		
Color variation (Mura)		Not visible through 5% ND filter.																		

Document No.	TQ3C-8EAF0-E3YAB42-00
Date	November 4, 2025

KYOCERA PACKAGING STANDARD

TYPE : TCG085WVLQHPNN-GN00

KYOCERA CORPORATION

Original Issue Date	Designed by: Engineering dept.			Confirmed by: QA dept.
	Prepared	Checked	Approved	Approved
November 4, 2025	<i>K. Komurasaki</i>	<i>Y. Hata</i>	<i>I. Kawajiri</i>	<i>T. Sawada</i>

Document No. TQ3C-8EAF0-E3YAB42-00	Part No. TCG085WVLQHPNN-GN00	Page -
---------------------------------------	---------------------------------	-----------

Revision record

Date	Designed by: Engineering dept.			Confirmed by: QA dept.
	Prepared	Checked	Approved	Approved
Rev. No.	Date	Page	Descriptions	

1. How to store LCDs in the pad

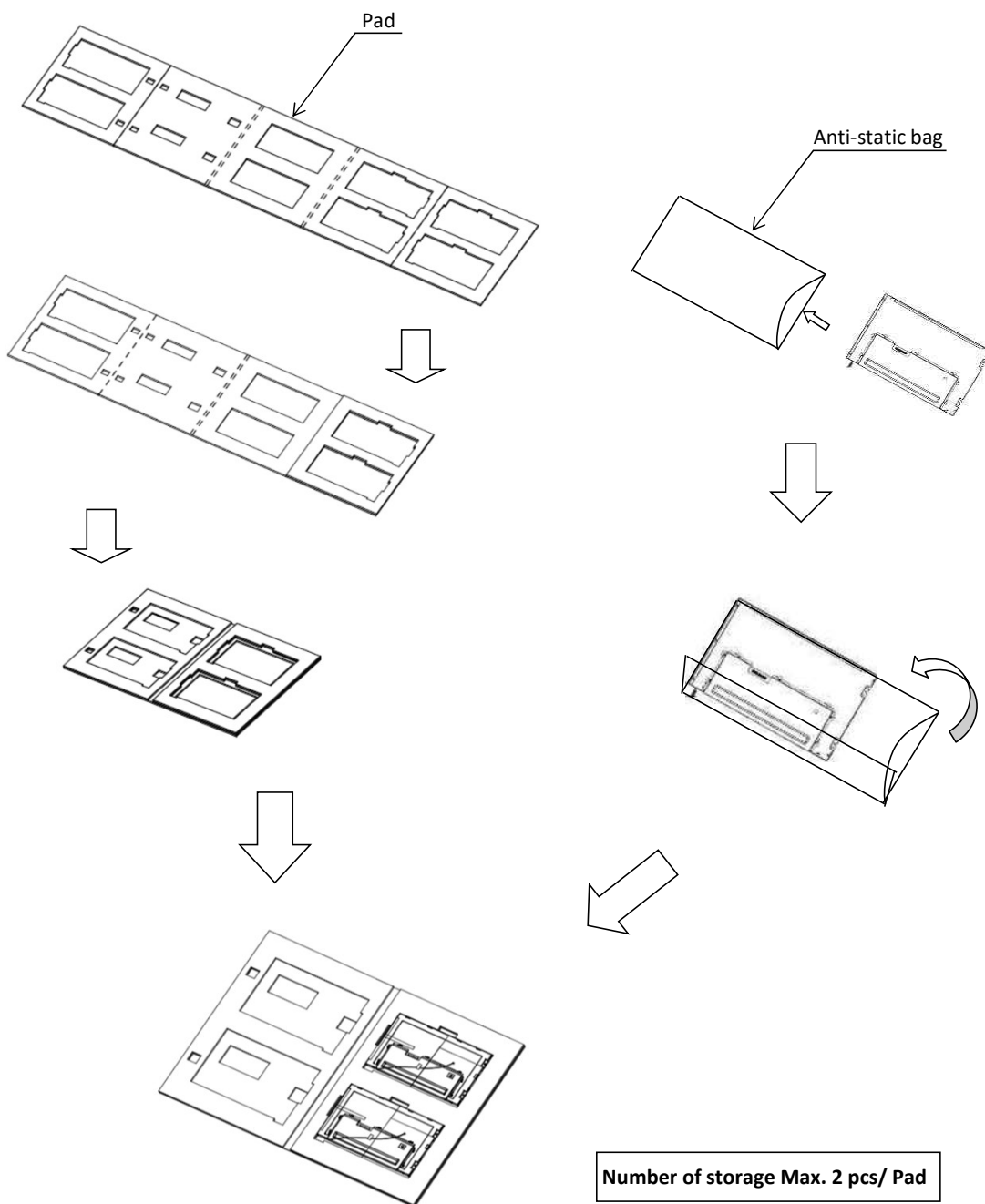

2. How to store LCDs in the outer case

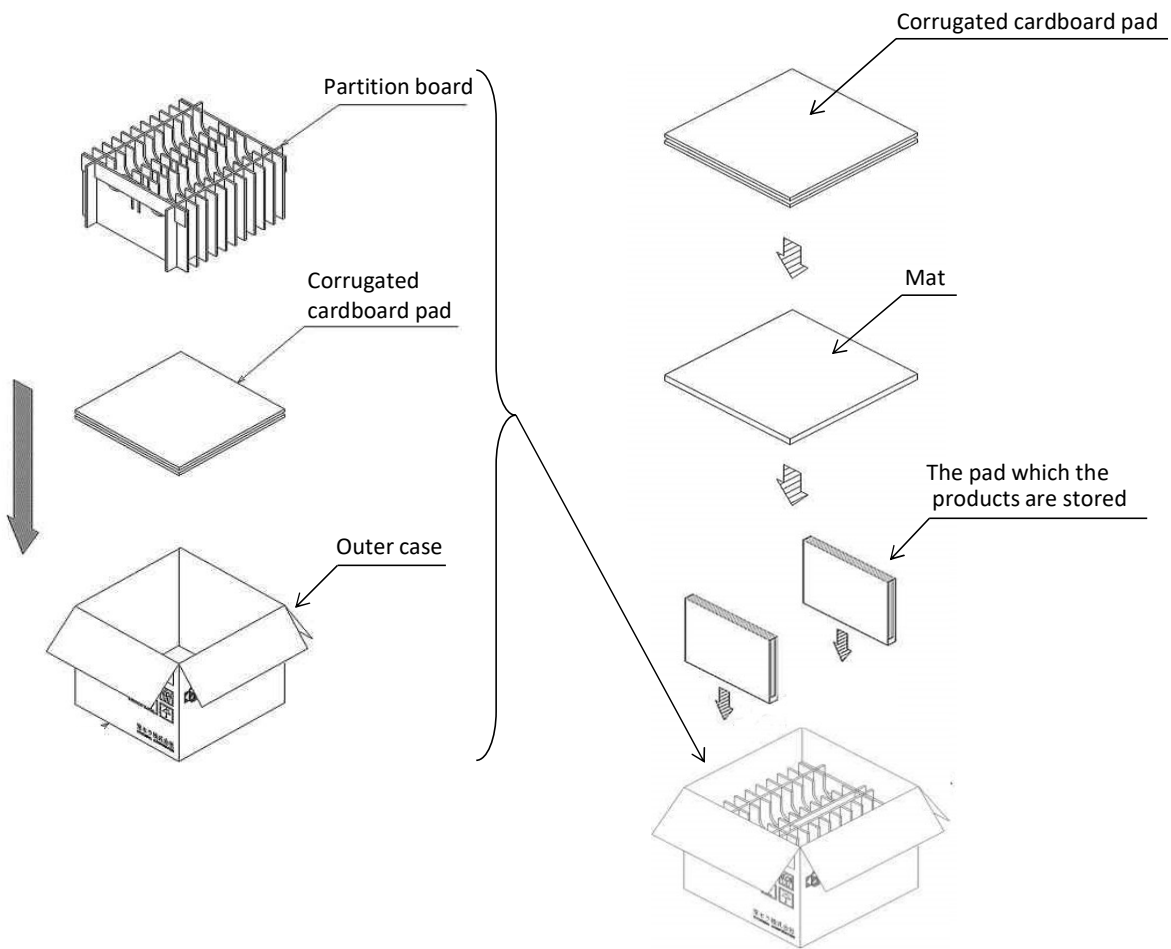

Number of storage Max.20 pcs/ Case

3. Location of the labels

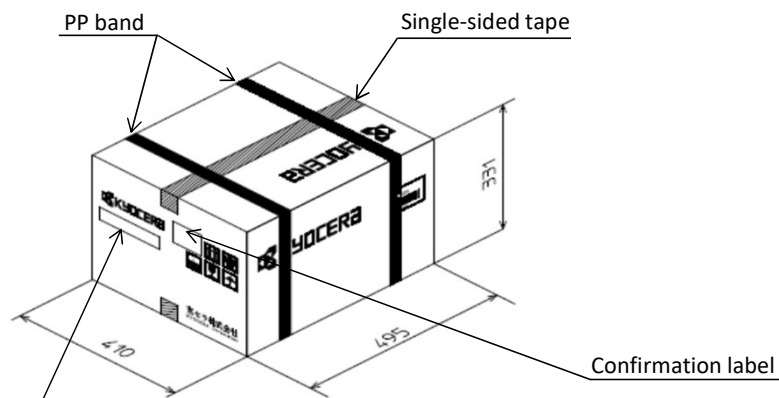

Shipping label

MODEL: 機種番号:	
P/N No: 部品番号:	
DESCRIPTION: 説明:	
PARTS NO. (S/N): パーツ番号:	
Quantity: 数量:	
	Lot No. (Lot No.): ロット番号:
	Date (Date): 日付:
KYOCERA CORPORATION	

客先 (Customer)			京セラ株式会社
品名 (Parts No.)			
数量 (Qty)			
検査者 (Check)			
検査者 (Check)			
検査者 (Check)			